

InMax ¼ turn actuators – size S

Electrical rotary actuators for use in safe areas

On-off control mode, 24...240 VAC/DC, 95° angle of rotation incl. 5° pretension

6 Nm, 12 Nm with safety operation: fast spring return ~ 1 s*

InMax - ... - F1
InMax - ... - SF1
InMax - ... - BF1
InMax - ... - CTS
InMax - ... - VAS

Subject to change!

Compact. Easy installation. Universal. Cost effective. Safe.

Type	Torque	Supply	Motor running time	Spring return*	Control mode	Feedback	Wiring diagram
InMax- 8 - F1	6 Nm	24...240 VAC/DC	3 / 15 / 30 / 60 / 120 s/90°	~ 1 s/90°	On-off	–	SB 2.4/2.5
InMax- 15 - F1	12 Nm	24...240 VAC/DC	3 / 15 / 30 / 60 / 120 s/90°	~ 1 s/90°	On-off	–	SB 2.4/2.5
InMax- 8 - SF1	6 Nm	24...240 VAC/DC	3 / 15 / 30 / 60 / 120 s/90°	~ 1 s/90°	On-off	2 × aux. switches	SB 2.4/2.5 + 3.2
InMax- 15 - SF1	12 Nm	24...240 VAC/DC	3 / 15 / 30 / 60 / 120 s/90°	~ 1 s/90°	On-off	2 × aux. switches	SB 2.4/2.5 + 3.2
InMax- 8 - BF1	6 Nm	24...240 VAC/DC	3 / 15 / 30 / 60 / 120 s/90°	~ 1 s/90°	On-off	2 × aux. switches + tripping circuit	SB 2.4/2.5 + 7.4
InMax- 15 - BF1	12 Nm	24...240 VAC/DC	3 / 15 / 30 / 60 / 120 s/90°	~ 1 s/90°	On-off	2 × aux. switches + tripping circuit	SB 2.4/2.5 + 7.4
InMax- ... - CTS	Types as above with aluminium housing and seawater resistant coating (cable glands brass nickel-plated)						
InMax- ... - VAS	Types as above with stainless steel housing for aggressive ambient (cable glands brass nickel-plated)						

*At low temperatures the spring return time might vary. For further assistance please contact our sales team.

Product views and applications

InMax-...-F1



Safety damper



Ball valve



Throttle valve



Description

The InMax actuators are a revolution for safety, control and shut-off dampers and other motorized applications for HVAC systems in chemical, pharmaceutical, industrial and offshore/onshore plants.

IP66 protection, small dimensions, only 3,5 kg weight, universal functions and an optional stainless steel housing guarantee safe operation even under difficult environmental conditions. High quality brushless motors guarantee long life.

All actuators are programmable and adjustable on site. Special tools or equipment are not required. Motor running times are selectable on site. The integrated universal power supply is self adaptable to input voltages in the range of 24...240 VAC/DC. The actuators are 100% overload protected and self locking.

...Max-...-F1 actuators are equipped with spring return fail safe function. Additionally the ...Max-...-SF1 and ...-BF1 actuators are equipped with 2 integrated, potential free auxiliary switches each and ...Max-...-BF1 comes with a tripping circuit for connecting the ...Pro-TT... safety temperature trigger. Standard shaft connection is a double square direct coupling with 12 × 12 mm.

Different accessories are available to adapt auxiliary switches, terminal boxes or adaptions for ball valves and throttle valves and other armatures.

Highlights

- ▶ Industrial use
- ▶ Universal supply unit from 24...240 VAC/DC
- ▶ 5 different motor running times 3–15–30–60–120 s/90°, adjustable on site
- ▶ On-off control with fast spring return function
- ▶ Circuit for direct connection of the ...Pro-TT... safety temperature trigger (type ...-BF1)
- ▶ 2 integrated auxiliary switches, switching at 5° und 85° (type ...-SF1 and ...-BF1)
- ▶ 100 % overload protected
- ▶ Compact design and small dimension (L × W × H = 210 × 95 × 80 mm)
- ▶ Direct coupling to the damper shaft with double square connection 12 × 12 mm
- ▶ 95° angle of rotation inclusive 5° pretension
- ▶ Robust aluminium housing (optional with seawater resistant coating) or in stainless steel
- ▶ IP66 protection
- ▶ Simple manual override included + preparation for comfortable manual override
- ▶ Gear made of stainless steel and sinter metal
- ▶ Weight only ~ 3,5 kg
- ▶ Integrated safety temperature sensor
- ▶ Integrated equipment for manual adjustment (push button, lamp, switch)
- ▶ Preparation for adaptable and adjustable auxiliary switches type ...Switch

Technical data	InMax- 8 - F1	InMax- 15 - F1	InMax-... - SF1	InMax-... - BF1
Torque motor (min.)	8 Nm	15 Nm	8 resp. 15 Nm	8 resp. 15 Nm
Torque spring (F)	~ 6 Nm	~ 12 Nm	~ 6 resp. ~ 12 Nm	~ 6 resp. ~ 12 Nm
Torque blockade	In blockade and end positions torques are higher than above specified torques for motor and spring.			
Dimensioning of external load	min. 2 Nm	min. 5 Nm	min. 2 resp. 5 Nm	min. 2 resp. 5 Nm
Supply voltage / frequency	24...240 VAC/DC \pm 10 %, self adaptable, frequency 50...60 Hz \pm 20 %			
Power consumption	max. starting currents see ① Extra information (in acc. with voltage, $I_{start} \gg I_{rated}$), approx. 5 W holding power, approx. 16 W waiting time electronic			
Protection class	Class I (grounded)			
Angle of rotation and indication	95° incl. ~ 5° pretension, mechanical value indication			
Working direction	Selectable by left/right mounting to the damper/valve shaft			
Motor running times	3 / 15 / 30 / 60 / 120 s/90° selectable on site			
3 sec. mode – motor	In acc. with the supply voltage and external torque 3 to 4 s/90° angle of rotation			
Motor	Brushless DC motor			
Control mode	On-off			
Spring return (F)	spring return upon voltage interruption or opening of line 3, response time up to 1 sec. after voltage interruption			
Spring return running time (F)	~ 1 s/90° (For usage at low temperatures please contact our sales team)			
Safety operations at 1 sec. (F)	min. 1,000 acc. to construction of damper and ambient. Consider minimum external load!			
Tripping circuit	...-BF1	Circuit to connect the InPro-TT-... safety temperature trigger directly to the actuator with M12 quick connection		
Aux. switches	...-SF1, ...-BF1	2 integrated auxiliary switches, switching at 5° and 85° angle of rotation, potential free. Grid fuse-protection is recommended!		
		U_{max}/I_{max} AC = 250 V/5 A; U_{min} AC/DC = 5 V; After one-time operation with $U > 24$ V AC/DC or $I > 100$ mA: U_{min} AC/DC = 12 V U_{max}/I_{max} DC = 48 V/1 A; I_{min} AC/DC = 5 mA; I_{min} AC/DC = 100 mA		
Axle of the actuator	Double square 12 x 12 mm, direct coupling, 100 % overload protected			
Electrical connection	Cable ~ 1 m, wire cross section 0.5 mm ² , equipotential bonding 4 mm ² . Connections require a terminal box!			
Diameter of cable	~ Ø 6.2 mm	~ Ø 6.2 mm	~ Ø 6.2 + 7.4 mm	~ Ø 9.3 mm
	2 cables in version ...-SF1			
Cable gland	M16 x 1.5 mm			
Manual override	Use delivered socket wrench, max. 4 Nm			
Housing material	Aluminium die-cast housing, coated. Optional with seawater resistant coating (...-CTS) or stainless steel housing, № 1.4581 / UNS-J92900 / similar AISI 316Nb (...-VAS)			
Dimensions (L x W x H)	210 x 95 x 80 mm, for diagrams see ① Extra information			
Weight	~ 3,5 kg aluminium housing, stainless steel ~ 7 kg			
Ambients	Storage temperature -40...+70 °C, working temperature -20...+50 °C			
Humidity	0...90 % rH, non condensing			
Operating 3 sec. motor run time	In 3 s mode the motor will work only after 1 minute of voltage supply. While open/close operation (open voltage supply and shut it down) motor works only with speed of 15 s/90°			
≥ 15 sec. motor run time	at 15 / 30 / 60 / 120 s 100 % of ED is permitted (ED = duty cycle)			
Maintenance	Maintenance free relative to function, maintenance must comply with regional standards, rules and regulations			
Wiring diagrams	SB 2.4 / 2.5	SB 2.4 / 2.5	SB 2.4 / 2.5 + 3.2	SB 2.4 / 2.5 + 7.4
Scope of delivery	Actuator, 4 screws M4 x 100 mm, 4 nuts M4, Allen key for simple manual override			
Parameter at delivery	30 s/90°	30 s/90°	30 s/90°	30 s/90°

Approbations

CE identification	CE
EMC directive	2014/30/EU
Low voltage directive	2014/35/EU
Enclosure protection	IP66 in acc. with EN 60529

Electrical connection

All actuators are equipped with a universal supply unit working at a voltage range from 24...240 VAC/DC. The supply unit is self adjusting to the connected voltage!
 The safety operation of the spring return function works if the supply voltage is cut or line 3 opened. For electrical connection a terminal box is required (e.g. InBox).
 An over-current protection fuse < 10 A has to be provided by installer.
 Note: the initial current is appr. 2 A for 1 second.
 Integrated auxiliary switches signal the rotation angle's position. U_{min} and I_{min} change once the switches were operated with higher voltage or current.

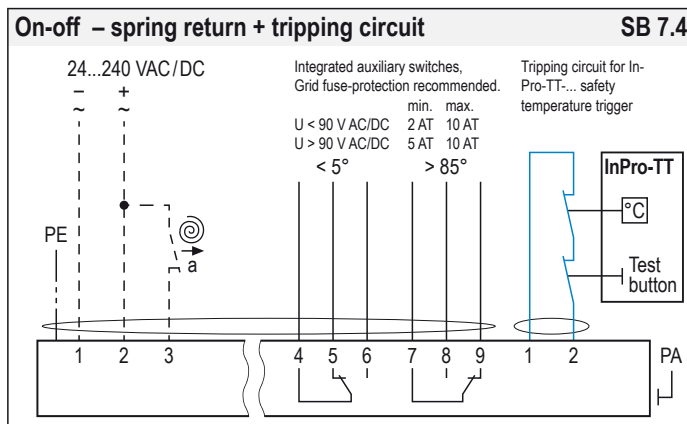
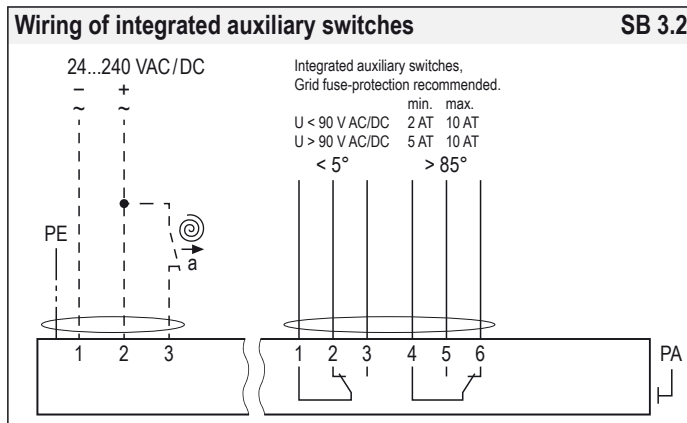
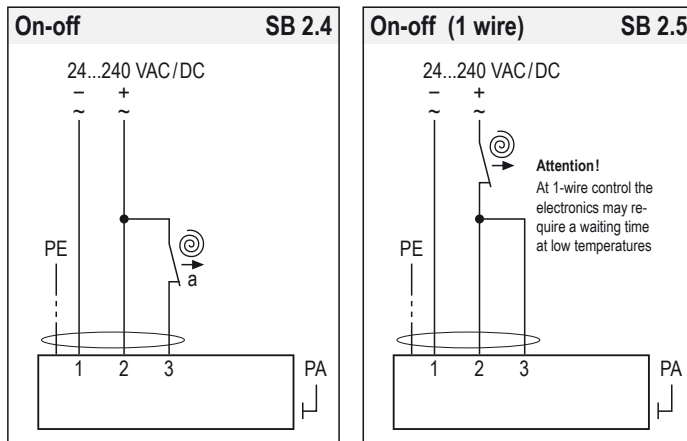

Attention
 During commissioning apply a self adjustment drive.
 Regard duty cycle at motor running times!
 Never use spring return actuators without external load.

Parameters, adjustments and failure indication

Switch – Push button – Lamp for adjustment (behind the blanking plug)

10-position switch (S)
 Push button (T)
 3-colour LED

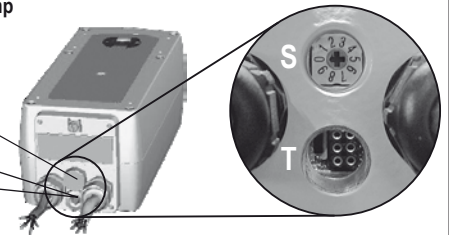

Parameter selection

Example:
 InMax-15-BF1
 Requested parameter:
 Torque 15 Nm
 Motor running time 30 s/90°

Type	Torques (motor)
InMax- 8-...F1	8 Nm
InMax- 15-...F1	15 Nm

Running times	Position of switch S
3 s/90°	00 05
15 s/90°	01 06
30 s/90°	02 07
60 s/90°	03 08
120 s/90°	04 09

Result:
 Switch position **02**

Functions, adjustments and parameters

A) Self adjustment of angle of rotation

ATTENTION: To adjust the angle of rotation connect only wire 1 and 2. Do not connect wire 3.

Apply supply voltage to wire 1 and 2. Turn switch (S) to position 02. Press push button (T) for a minimum of 3 seconds. The actuator drives to the first end position, detects the blocking position and performs a spring return to the starting position. The LED flashes GREEN during adjustment. After that disconnect from the mains and connect wire 3.

The adjustment takes about 31 seconds (30 sec. "On", 1 sec. "Off").

B) Selecting motor running time

Adjust parameters only if actuator is in idle state or without applied potential. Turn switch (S) to the position required for the intended operation acc. to table above. The selected parameters will be carried out at the actuator's next operation.

C) Function of the InPro-TT... in the tripping circuit

When the ...Pro-TT's tripping circuit is opened the actuator runs into its end position with spring return.

D) Additional information for control in On-off operation

a closed = actuator opens
 a open = spring return

The rotation direction (clockwise/counter clockwise) depends on left/right mounting of the actuator to the damper.

Installation

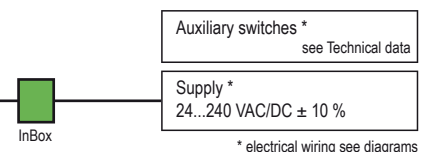

Important information for installation and operation

A. Installation, commissioning, maintenance

All national and international standards, rules and regulations must be complied with. Apparatus must be installed in accordance with manufacturer instructions. If the equipment is used in a manner not specified by the manufacturer, the safety protection provided by the equipment may be impaired.

For electrical connection a terminal box is requested (e.g. InBox-...).

Attention: If the actuator is put out of operation all rules and regulations must be applied. You have to cut the supply voltage before opening a terminal box!

The cable of the actuator must be installed in a fixed position and protected against mechanical and thermal damage. Connect potential earth. Avoid temperature transfer from armature to actuator! Close all openings with min. IP66. For outdoor installation a protective housing against sun, rain and snow should be applied to the actuator. The waiting time of the electronics at low temperatures can be minimized by a constant voltage supply to terminals 1 and 2. During commissioning apply a self adjustment drive. Actuators are maintenance free. An annual inspection is recommended. Actuators must not be opened by the customer.

B. Manual override

Manual override only if supply voltage is cut. Use delivered socket wrench with slow motions, usage can be tight.

Attention: Releasing or letting go the Allen key too fast at manual operating actuators with spring return causes risk of injury!

C. Shaft connection, selection of running time

Actuators are equipped with a direct coupling double square shaft connection of 12 x 12 mm. For round shafts adaptors/clamping connection (accessories, e.g. KB-S) are available. The housing of the actuator is axially symmetrically built to select Open-close direction of the spring return function by left-right mounting. Using the 10-position switch different motor running times and spring return running times can be selected on site in acc. to the actuator type.

D. Temperature trigger ...Pro-TT...

The actuator ...Max-...-BF1 will work only with the temperature trigger InPro-TT-...

E. Operation with 3 sec. motor running time

Note following:

1. The 3 sec. motor running time mode is only available in switch position 0 and 5 and at a constant supply voltage applied for a minimum of 1 minute on terminal 1 and 2.
2. The actuator opens at voltage on terminal 3 (resp. closes) and closes at voltage on terminal 4 (resp. opens) – depending on mounting position of the actuator.
3. The max. duty ratio is 10 % resp. 1 cycle/minute. Between two fully 3 sec. cycles in the same direction there must be a minimum intermission of 1 minute. Trying to run the actuator in the same direction in less than the required minimum of 1 minute the function will be blocked for the rest of the idle period. Later the release for the next cycle is made automatically by an internal timing relay.
4. Same function is applied on spring return actuators, fail safe operation is regarded same as a motor running cycle.
5. Trying to use the 1 wire On-off method in switch position 0 and 5, software changes the motor running time temporarily and automatically to 15 s/90° to protect the actuator for overheating due to uncontrolled duty ratio.

F. Spring return

Spring return function works only if the supply voltage for terminal 1 or 2 is cut. In the event of an electrical interruption, the spring returns to its end position even if supply voltage is available again during return function. Thereafter operation will continue.

G. Operation at low ambient temperatures

The spring return time at low temperatures might vary. Please contact our sales team for further information.

H. Excess temperatures

All actuators are protected against excess temperature. The internal thermostat works as a maximum limiter and, in the event of failure at incorrect temperatures, shuts off the actuator irreversibly. An upstream connected temperature sensor stops the actuator before reaching its max. temperature. This safety feature is reversible, after cooling down the actuator is completely functional again. In this case the failure must be eliminated immediately on site!

I. Synchron mode

Do not connect several actuators to one shaft or link mechanically together.

J. Mechanical protection

Actuators must be operated with a minimum external load.

After installing the actuator to the damper/armature a self adjustment drive has to be performed in order to protect the damper/armature against mechanical overload. During operation the actuator reduces briefly its speed (motor power) before reaching the end position for a "gentle" blockade/stop.

K. Routine tests of fire dampers

For periodic inspection of fire dampers cut off the supply line (current of actuator). The test button at InPro-TT-... is only for test aims of actuator's function.

Extra information (see additional data sheet)

Additional technical information, dimensions, installation instruction, illustration and failure indication

Special solutions and accessories

...-CTS	Types in aluminium housing with seawater resistant coating, parts nickel-plated
...-VAS	Types in stainless steel housing, parts nickel-plated
Adaptions	for dampers and valves on request
InMax-...-S3	Ambient temperature up to +60 °C, 110...240 VAC/DC, 25 % ED
InPro-TT-...	Safety temperature trigger for fire dampers

InBox-...	Terminal boxes
MKK-S	Mounting bracket for boxes type ...Box-... directly on actuator
InSwitch	2 external aux. switches, adjustable
KB-S	Clamp for damper shafts Ø 10...20 mm and □ 10...16 mm
AR-12-xx	Reduction part for 12 mm square connection to 11, 10, 9 or 8 mm shafts
BSH-S	Mounting holder for actuators in fire danger areas
Kit-S8	Cable glands nickel-plated



Extra information for ...Max actuators – size S

for optimization of planning, installation and initial startup for safe operation



Assembly

- ▶ Dimensions, drill plate
- ▶ Control elements: switch – push buttons – LED
- ▶ Outdoor installation
- ▶ Mounting on air dampers (form-fit and force-fit)
- ▶ Mounting on fire dampers (form-fit)
- ▶ Mounting on butterfly valves and ball valves
- ▶ Mounting of terminal box ...Box and auxiliary switch ...Switch



Electric

- ▶ Power supply design
- ▶ Line cross sections
- ▶ Problem treatment/error indication

Subject to change!

▶ Dimensions

Dimensioning in mm

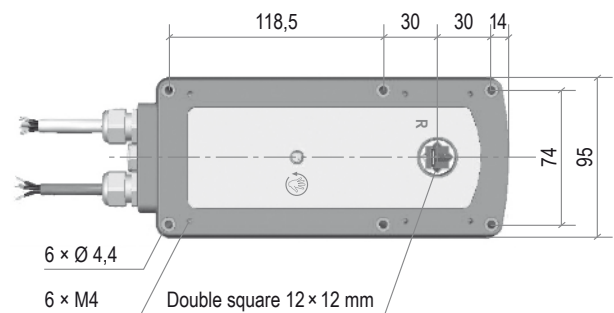
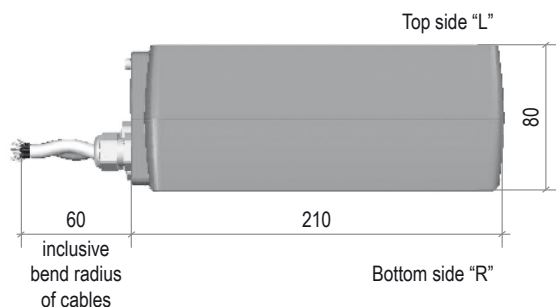

▶ Control elements: switch – push button – LED

All actuators are equipped with a 10-position switch, a push button and a multicolour LED for calibration. These control elements are to be found cable-laterally behind the two middle sectioned dummy plugs. For operation these must be removed. The calibration can be achieved despite lining up power supply at the actuator. The explosion prevention is not impaired thereby. However, it has to be of great concern that the dummy plugs must be rescrewed in order to comply with the IP-protection class.

The operation of the switch and button has to be done by means of a small screwdriver. Force with strong pressure and/or rotation is to be avoided in any case, since otherwise control electronics can be damaged irreparably. Adjustments of torque and running time can be achieved also before mounting. The adjustment of angle of rotation can be started only with an outside load and accurate mounting.

Switch – Push button – Lamp for adjustment (behind the blanking plug)

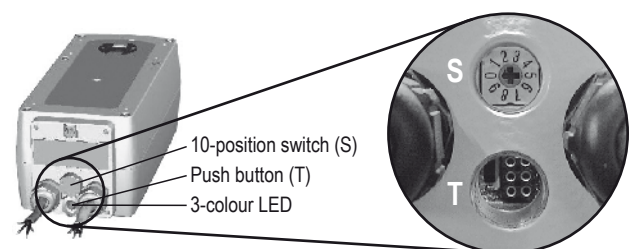

▶ Outdoor installation

When mounting actuator outdoors it has to be certain that the actuator is protected against direct sun exposure (heat and UV!), rain and snow by employing an enclosure roof. Supply voltage is to be applied immediately after mounting in order to assure integrated heating at start.

Since actuators must have an internal temperature fuse, they may not be exposed to a too high temperature, neither at storage nor during operation. Otherwise the fuse could respond and switch off the actuator irreversibly.

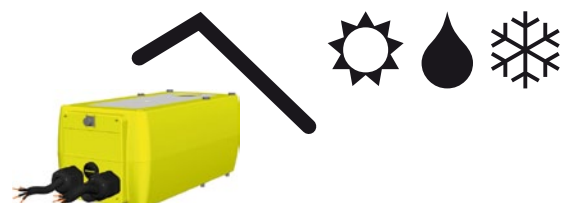

► Mounting of ...Max actuators



...Max actuators size S are equipped with a 12 × 12 mm (double square) shaft connection by default. The form-fitting shaft connection is the most secure connection between damper shaft and actuator because slipping or slipping through is avoided compared to the force-fit clamp-connection.

The actuator will be connected firmly to the damper or fixed to a mounting bracket by means of four screws M4 × 100 mm (scope of delivery).

For connection to round or square damper shafts smaller or larger than 12 × 12 mm a tensionally locked connection can be realized with the mounting clamp "KB-S" (optional accessory).

For square damper shafts 8 × 8 mm, 9 × 9 mm, 10 × 10 mm or 11 × 11 mm reducing bushes are also available.

The actuators are axially symmetric developed. In case of spring return function the safety position must be selected by turning the actuator to 180°.

Furthermore it is to be considered that the actuators have a total angle movement of approx. 95° in order to realize a pretension on the control element (damper or the like).

Therefore the actuator sits tilted on the damper shaft.

In order to adjust this and to induce pretension, the driving shaft has to be aligned mechanically over the hand-operated control socket "HV" when connecting to the damper shaft.

The socket wrench has to be turned **counterclockwise** when facing the actuator's "side R", facing "side L" turn manual override **clockwise**.



Attention: Mount with appropriate safety precautions only!

- The drive shaft is self-locking and may only be mechanically adjusted either with the provided socket wrench or the optional accessory "HV-S" manual override (turn off power supply). External force applied to the shaft can lead to mechanical damage of the actuator!
- At the manual override counteracting forces occur when mounting spring return actuators. **Do NOT release manual override under spring tension!**

► Mounting on air dampers



Form-fitted shaft connection – Mounting on square damper shaft

Mounting:

1. Affix tap holes M4 (in accordance with drill template) on the damper or to a mounting bracket.
2. Adjust drive shaft of the actuator with the socket wrench that the drive stands perpendicularly to the damper before plugging actuator onto the damper shaft.
3. Plug actuator onto damper shaft and fix diagonally with 2 screws.
4. Remove the socket wrench.
5. Pivot and tighten the remaining screws.

Dimension of the damper shaft

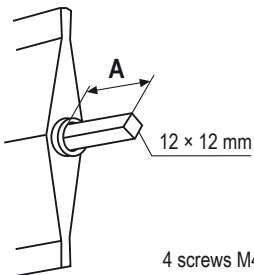

Length A

Measure A in acc. with indicator:

- | | |
|--|---------------------|
| 1. Actuator without indicator | A = no limit |
| 2. Actuator with indicator, no accessories | A < 65 mm |

4 screws M4 × 100 mm as well as a socket wrench are part of delivery. For square damper shafts 8 × 8 mm, 9 × 9 mm, 10 × 10 mm or 11 × 11 mm reducing bushes are available as optional accessories.

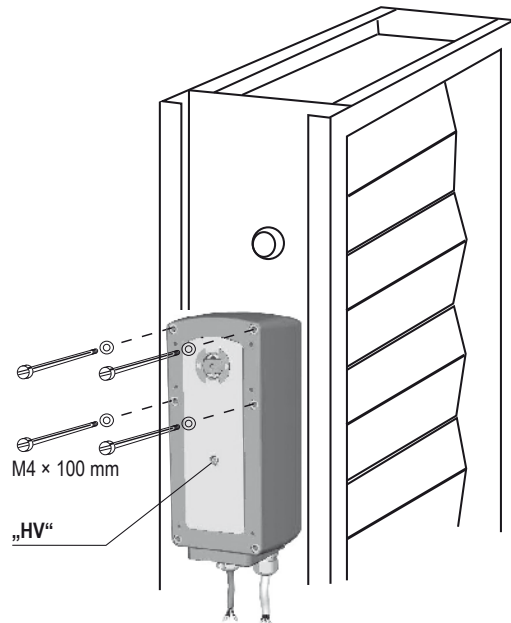

Force-fitted shaft connection – Mounting of clamp "KB-S"

Mounting:

1. Insert mounting clamp into drive shaft and screw tightly from opposite side with the socket wrench.
2. Screw in two screws functioning as an anti-twist locking device.
3. Install mounting bracket at the damper.
4. Mount actuator on the damper shaft, adjust it in the mounting bracket and install it in such way that it can implement an oscillating motion for the reconciliation of the non-centric connection. Tighten the clamp with the wrench socket.

1. Pre-assemble mounting clamp

2. Fixing

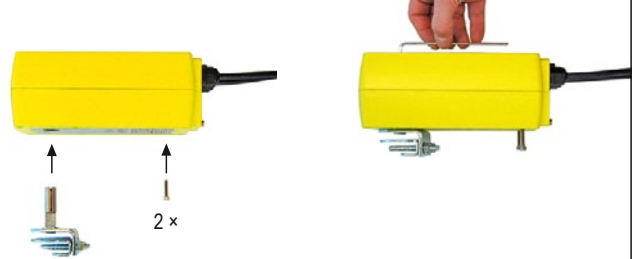

3. Assemble mounting bracket

4. Mounting to damper



Round damper shafts

Square damper shafts

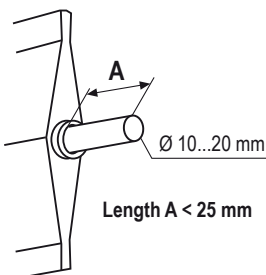

Length A < 25 mm

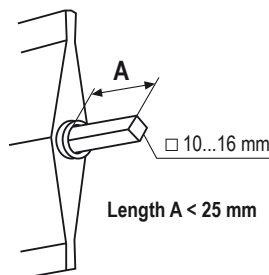

Length A < 25 mm

► **Mounting on fire dampers**



ExMax-...-BF and RedMax-...-BF actuators integrate an intrinsically safe circuit in order to connect an ExPro-TT-... sensor which works like a temperature trigger. InMax-... and InPro-TT-... are for non hazardous areas.

Mounting:

1. Affix tap holes M4 (in accordance with drill template) on the damper or to a mounting bracket
2. Adjust drive shaft of the actuator with the socket wrench that the drive stands perpendicularly to the damper before plugging actuator onto the damper shaft
3. Plug actuator onto damper shaft and fix diagonally with 2 screws
4. Remove the socket wrench
5. Pivot and tighten the remaining screws
6. Mount temperature trigger ...Pro-TT-...
7. Mount terminal box (type ...Box-BF)
8. Plug sensor connector into actuator's socket



Connection of safety temperature trigger ...Pro-TT-...



The temperature trigger is mounted directly to the duct or damper wall with pre-assembled tapping screws. The position of the safety elements must guarantee free air flow. ...Pro-TT-... is mounted to the actuator by means of quick fastener M12.

► **Mounting to ball valves and butterfly valves**



Actuators of size S are equipped by default with a 12 × 12 mm double square form-fitting shaft connection. For mounting to butterfly valves or ball valves a special mounting bracket in acc. with DIN EN ISO 5211 is required.

Since this standard provides only certain basic conditions there can be substantial geometrical differences between armatures which require a special adaption.

Mounting to a ball valve

Mounting to a butterfly valve

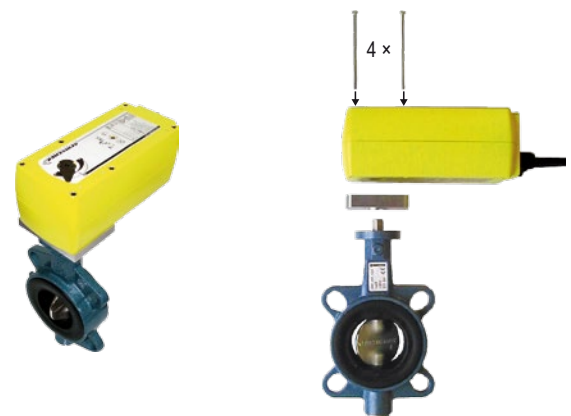
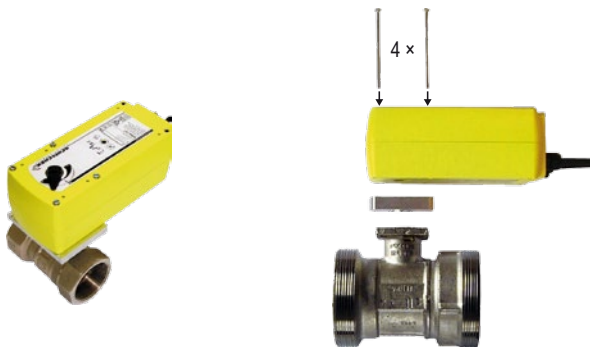

► Mounting of terminal boxes ...Box to actuator via mounting bracket MKK-S (accessory)



- A) Screw mounting bracket MKK-S with 4 screws to actuator
- B) Screw terminal box to mounting bracket

Mounting bracket can be mounted every 90°

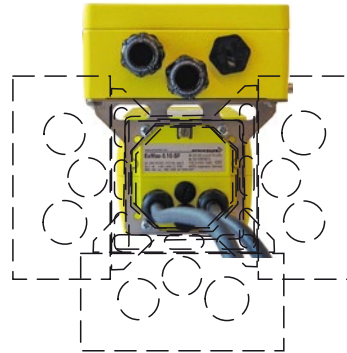
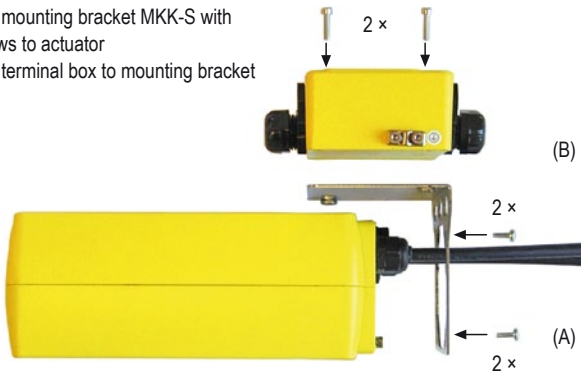

Terminal box mounted above the actuator

Terminal box mounted beside the actuator

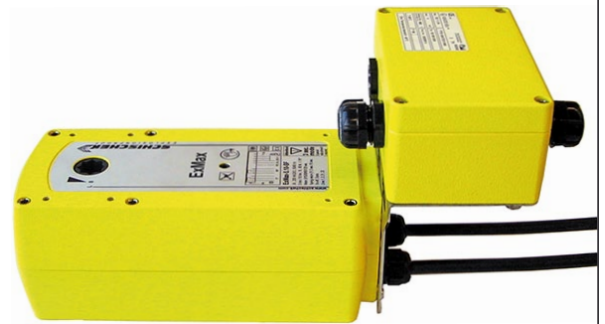

► Mounting of auxiliary switch ...Switch to actuator



- A) Place square connection part on actuator's shaft
- B) Mount ...Switch and fix it with screws

...Max with mounted ...Switch

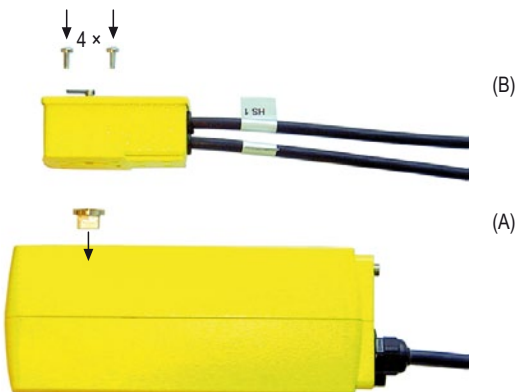

► Power input depending on supply voltage

The design of the on-site supply depends on the selected motor running time and selected supply voltage. Accompanying values are "about values" since there can be construction unit dispersions within electronics. The holding power is run time independently typical at ~ 5 W. The power consumption for the heater is ~ 16 W. In the heating phase the motor is not active!

The initial starting supply voltage required by the actuators power supply unit is ~ 2.0 A. The starting pulse takes about 1 sec. (please consider this while conceiving the cross section of the supply line). The power factor is between 0.8 and 0.5 in dependence of motor running time. A line protection should be min. 2 AT.

Voltage	Current	Rated current in acc. with motor running time				
		3 / 7,5 s	15 s	30 s	60 s	120 s
24 V DC	I _{Nominal}	4,70 A	1,30 A	0,70 A	0,60 A	0,50 A
120 V AC	I _{Nominal}	0,75 A	0,30 A	0,25 A	0,20 A	0,17 A
240 V AC	I _{Nominal}	0,37 A	0,15 A	0,12 A	0,10 A	0,08 A

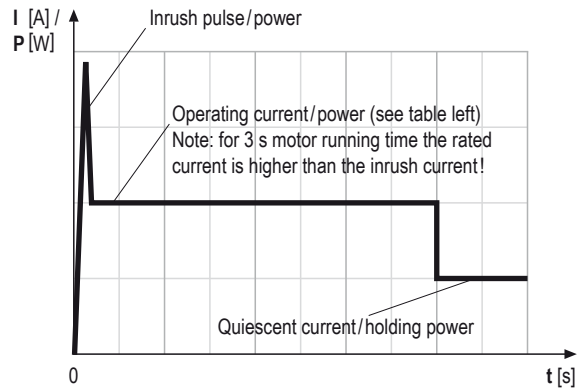

► Cross sections of the inlet line

On long distances between voltage supply and drive, voltage drops occur due to line resistances. As a consequence with 24 VAC/DC the actuator receives a too low tension and does not start. In order to prevent this the cross section of the inlet line is to be dimensioned accordingly.

The accompanying formulas allow the calculation of the necessary line cross section respectively maximal permitted conduit length respectively utilizing the existing line cross section.

Alternatively the secondary voltage can be increased by selecting a transformer.

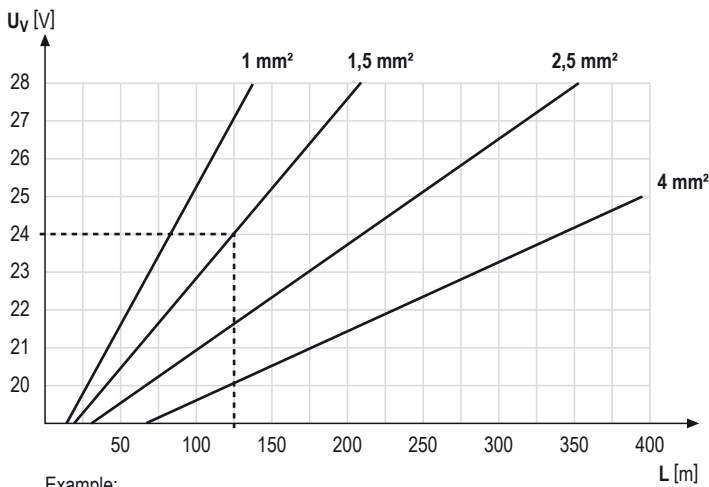
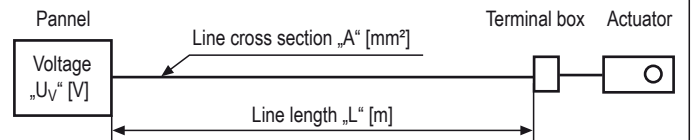

Example:
24 V power supply with wire diameter 1,5 mm² = cable length 126 m

Required cable cross section A at existing cable length L

$$A = 0,0714 \times L : (U_V - 18 V)$$

Example: L = 250 m, U_V = 30 V
Cross section A = 1,5 mm²

Maximum cable length L at existing cross section A

$$L = A \times (U_V - 18 V) : 0,0714$$

Example: A = 1,5 mm², U_V = 24 V
Length of cable L = 126 m

For calculation following characteristics are essential:

U_V = supply voltage [V]

A = line cross section [mm²]

L = conduit length [m]

Factor 0,0714 = drive specific factor [Vmm²/m]

(based on the electrical conductivity of electrolytic copper with a coefficient of 56 m/Ωmm²)



► Problem handling / Error indication



Problem	Possible cause	Course of action
01 Actuator does not work LED does not light	<ul style="list-style-type: none"> No power supply attached The actuator is operated at ambient temperature beyond specifications and the internal temperature fuse shuts down irreversibly 	<ul style="list-style-type: none"> Attach power supply and turn on Caused by inadmissible operation and for safety relevant reasons the actuator drove into an irreversible condition and must be exchanged. Accompanying new installation the ambient temperature has to be reduced accordingly
02 Actuator does not work LED lights RED	<ul style="list-style-type: none"> The actuator is operated at a too high ambient temperature and the internal temperature sensor responded ...-BF actuators require a temperature trigger type ...Pro-TT or FireSafe 	<ul style="list-style-type: none"> Shut off actuator and let temperature decrease, reduce ambient temperature by suitable measures e.g. ventilation or other mounting position of the actuator Connect trigger, LED changes to GREEN, actuator is ready-to-operate
03 Actuator does not work LED lights GREEN	<ul style="list-style-type: none"> 3-pos. control signal is wired on both entrances Required torque is greater than actuators torque Control signals are not attached or attached on a wrong conductor Actuator is incorrectly mounted and is blocked by an external stop unit Interchanged supply lines 	<ul style="list-style-type: none"> Readjust / correct circuit Adjust a higher torque at the actuator if possible otherwise exchange for a type with higher torque Examine rule and adjusting signals and connect in accordance with diagram Dismount actuator and testdrive without load for operability. Then install actuator accordingly so that the power transmission of the actuator runs the armature/damper without external blockade or torsion Switch wires: 1 must be connected to (-, N) and wire 2 to (+, L)
04 Actuator does not work LED is blinking RED	<ul style="list-style-type: none"> The actuator has been mounted at temperatures < -20 °C and did not reach its operating temperature of at least -20 °C 	<ul style="list-style-type: none"> Ensure that a constant voltage supply is applied on conductor 1–2 Wait until the required operating temperature is achieved by the actuators internal heating system. The actuator will start operating independently
05 Spring return function is 10 s/90°, however should amount to 3 s/90°	<ul style="list-style-type: none"> Bridge 2–5 is not established 	<ul style="list-style-type: none"> Bridge conductor 2 of the constant voltage supply with conductor 5
06 Spring return function is 3 s/90°, however should amount to 10 s/90°	<ul style="list-style-type: none"> Bridge 2–5 is established 	<ul style="list-style-type: none"> Disconnect bridge
07 Actuator does not start after more than 2 briefly following adjusting functions were set in 3-sec. mode	<ul style="list-style-type: none"> The maximal permissible cyclic duration of 10 % ED (ED = duty cycle) in 3-sec. mode was not complied with, the actuator is in a safety disconnection mode 	<ul style="list-style-type: none"> Wait approx. 1 minute until internal electronics cool down to operating temperature
08 Y-actuators in 3-pos. mode cannot gear into intermediate positions	<ul style="list-style-type: none"> The conversion of constant mode to 3-pos. mode was not set 	<ul style="list-style-type: none"> Recalibrate the actuator in accordance with assembly instructions
09 Actuator sits diagonally on square damper shaft	<ul style="list-style-type: none"> Actuators have an angle of rotation of 95° incl. 5° pretension. While assembling the pre-load was not considered 	<ul style="list-style-type: none"> Dismount actuator off the damper, use enclosed socket wrench to draw up approx. 5° over the hand operated control device before remounting on the damper shaft. Consider assembly instructions!
10 Actuator is installed force-fit with shaft connection KB-S onto damper shaft and drives only partially or not at all	<ul style="list-style-type: none"> Provided that the electrical basic conditions specified above are fulfilled, the anti-twist plate could be installed in a way that the actuator blocks itself due to the twisted and off-centered shaft connection and therefore interlocks 	<ul style="list-style-type: none"> Loosen the anti-twist plate and remount so the actuator can implement an easy oscillating motion over its angle of rotation
11 A modulating Y-actuator working with reduced angle of rotation, reaches its end positions already at > 0 V/4 mA resp. < 10 V/20 mA	<ul style="list-style-type: none"> At start up no self-adjustment of angle of rotation was accomplished 	<ul style="list-style-type: none"> Accomplish self adjustment of angle of rotation in accordance with assembly instruction
12 LED flashes irregularly and actuator does not work	<ul style="list-style-type: none"> Actuator does not receive sufficient supply voltage Cable too long, voltage drop in the supply line too large 	<ul style="list-style-type: none"> Increase line cross section or power supply Increase line cross section or power supply

SALES CONTACT



www.airmax-hvac.com



080-614-4944, 063-268-8080



@airmax (Line Official)



windcontrol.info@gmail.com



Address

เลขที่ 56/392 หมู่ที่ 12
ตำบลศีรษะจรเข้น้อย
อำเภอบางเสาธง
จังหวัดสมุทรปราการ
10540